

Holistic **Air-Management** Systems

Turbocharger and Exhaust Gas
Treatment Portfolio

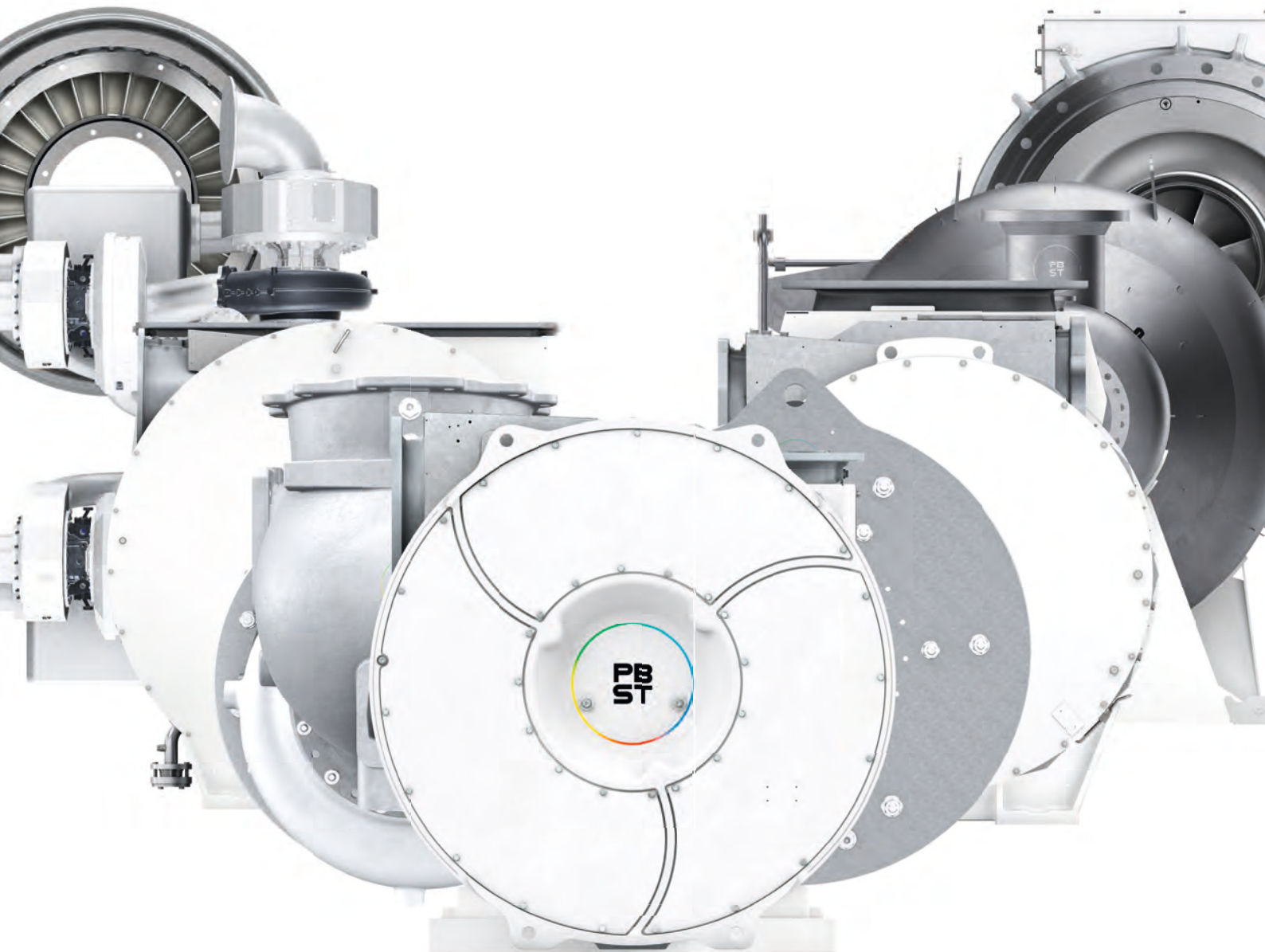



PBST is your dependable partner for holistic air and future fuel management systems. We provide advanced and inspiring air-management systems for applications in marine and rail, as well as stationary and off-road.

PBST has its roots in Germany and the Czech Republic and has more than 85 years of experience in designing and manufacturing turbochargers. We push the limits to create high performance technologies, such as single and two-stage turbocharging, injection systems, the EGR blower and SCR Systems, for all applications, in order to meet current and future challenges for our customers. Global after-sales services are provided by MAN PrimeServ.

 **85 years**
↗ of experience in designing and
manufacturing turbochargers



The only

↗ manufacturer capable of
delivering turbochargers,
exhaust gas solutions and
injection systems

Advanced turbocharging

We develop and build our turbochargers to make installation, operation, servicing and maintenance as easy and efficient as possible.

Our successful past as member of one of the world's leading engine manufacturers has taught us to align turbocharger specifications with engine requirements down to the very detail. We have a comprehensive product portfolio, and are proven experts in precisely matching the right turbocharger to each engine. As a global leader in pioneering turbocharger technology, we have built our reputation on the quality, efficiency and reliability of our products.

Inspiring solutions to reduce emissions

PBST is the only manufacturer capable of delivering turbochargers, injection systems and exhaust gas solutions. Selective Catalytic Reduction (SCR) is an after-treatment method that uses a catalyst and an additive to reduce the NO_x generated by the combustion process, while exhaust gas recirculation (EGR) is an internal engine process that prevents the formation of NO_x by controlling the combustion process. This unique portfolio allows customers to choose their preferred option as best fits their situation.

Yet we continue to develop new solutions for many applications. SCR-LP Systems are available for 4-stroke engines, for which it can already reference more than 650,000 operating hours. A compact and flexible design for easy installation ensures that our customers enjoy the highest standards of safety and reliability as well as lower lifecycle costs.

Dependable partner for the entire lifetime

We understand that an equal partnership does not stop once a product is delivered. To ensure, that you enjoy your PBST product to the fullest extent - even under rough conditions - we provide high quality service. MAN PrimeServ is PBST's authorized service partner and offers our customers global after-sales services for the entire product portfolio.

Contents

Turbochargers



→ TCR 10



→ TCT 14



→ TCA 18



→ TCP 22



→ TCF 26



→ Ecocharge 30

PBST turbocharger technology

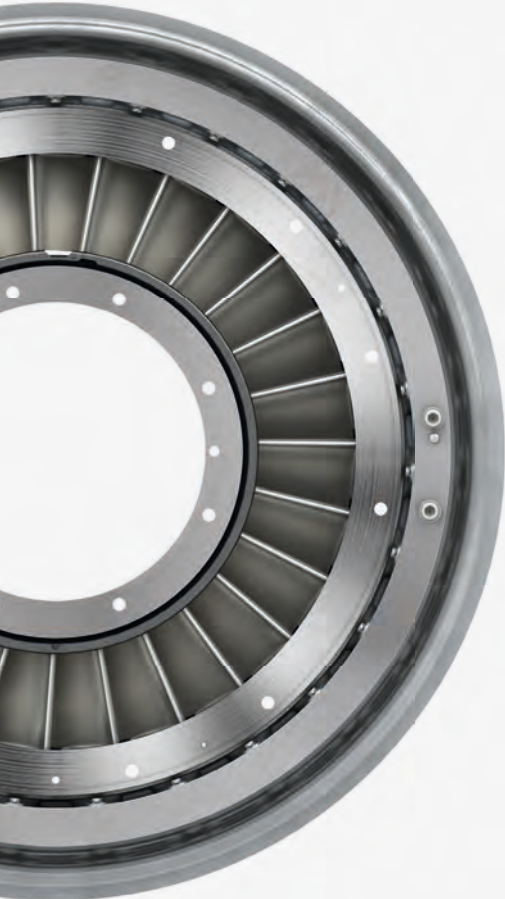

→ VTA

34

Exhaust gas treatment

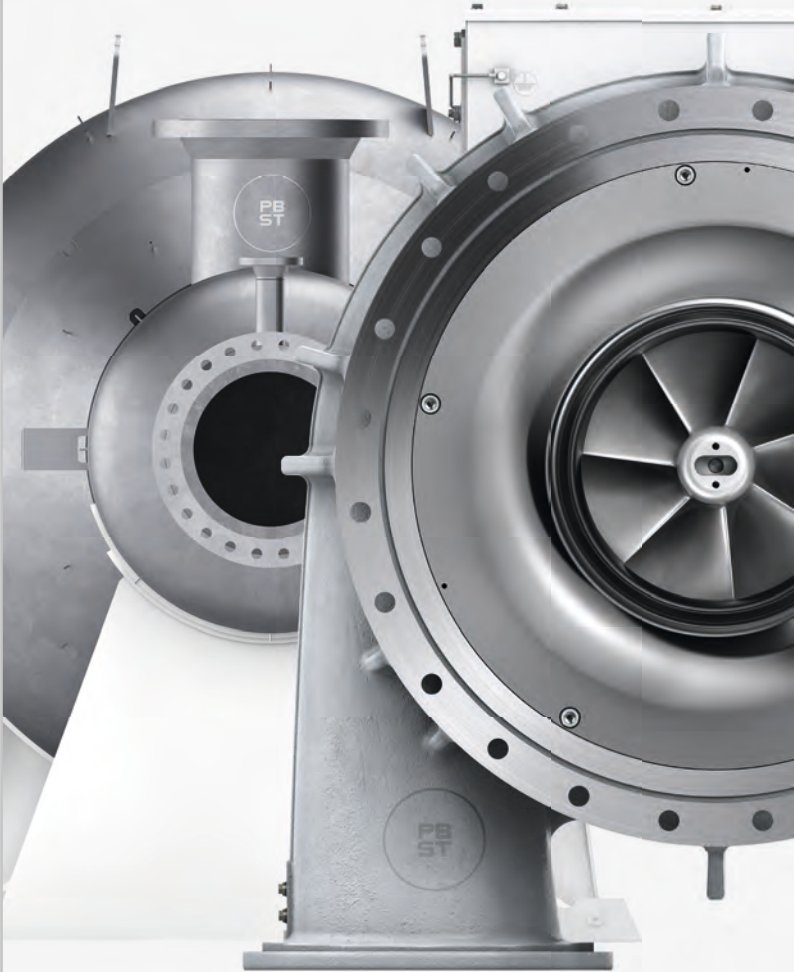

→ SCR
→ ETB

36
40

Injection systems



Service



The specialist performer

TCR

TCR turbochargers were created to address the very special challenges faced by HFO, MDO, biofuel and gas engines. Products are available for the entire engine power range, from 350 kW to 7 MW per turbocharger. The design is optimized for IMO Tier III requirements in whatever solution customers require, and represents a robust, versatile modular platform – suitable for a wide variety of high, medium and low speed engine applications.







Smaller, lighter, more powerful

The latest generation of TCR turbochargers offers reduced size and weight while delivering greater efficiency, performance and reliability. Advanced materials ensure extended overhaul intervals, easier maintenance and a longer lifetime.

Applications

- **4-stroke**
- **2-stroke**
- **Power generation**
- **Locomotive**
- **Marine**
- **Industrial**
- **Biogas plants**
- **Mining**

Benefits

- **Modular design**
Fulfills all relevant engine requirements
- **Easy to maintain and service**
Maintenance can be carried out with standard tools
- **Variable turbine area optionally available**
Airflow through TCR turbochargers can be controlled by VTA technology
- **Condition-based component maintenance**
Parts are replaced on the basis of component condition, increasing component life and lowering costs
- **Easy installation**
Compact, pipeless design ensures easy installation

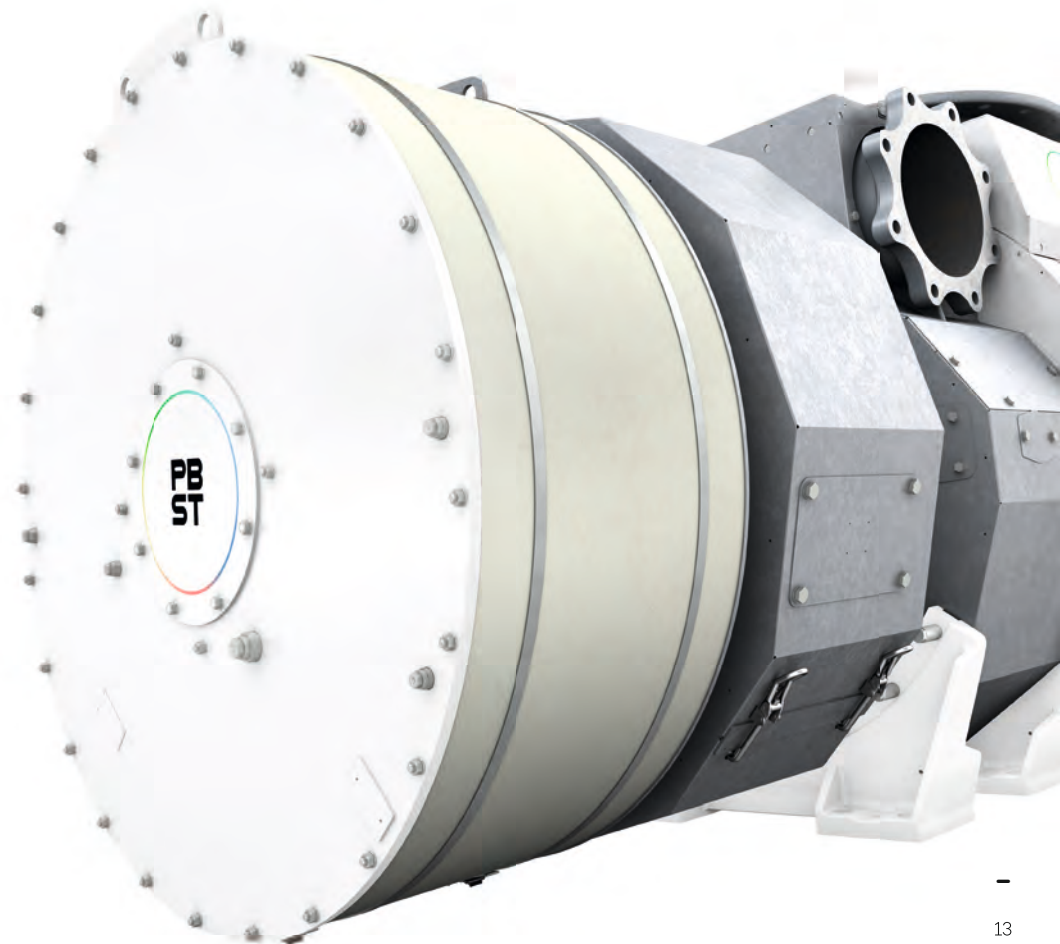

State of the art solution

TCT

TCT turbochargers are suitable for both conventional and dual-fuelled, 2- and 4-stroke engines in marine and power applications. TCT is also the enabler for two-stage turbocharging systems. The core components of the TCT are the compressor and the turbine. PBST's turbocharger experts used computational flow simulations (CFD) that make it possible to achieve multiple targets at the same time: wide compressor maps, high flow rates, high stability margins and exceptionally high efficiencies. The design is optimized for IMO Tier III requirements in whatever solution customers require.

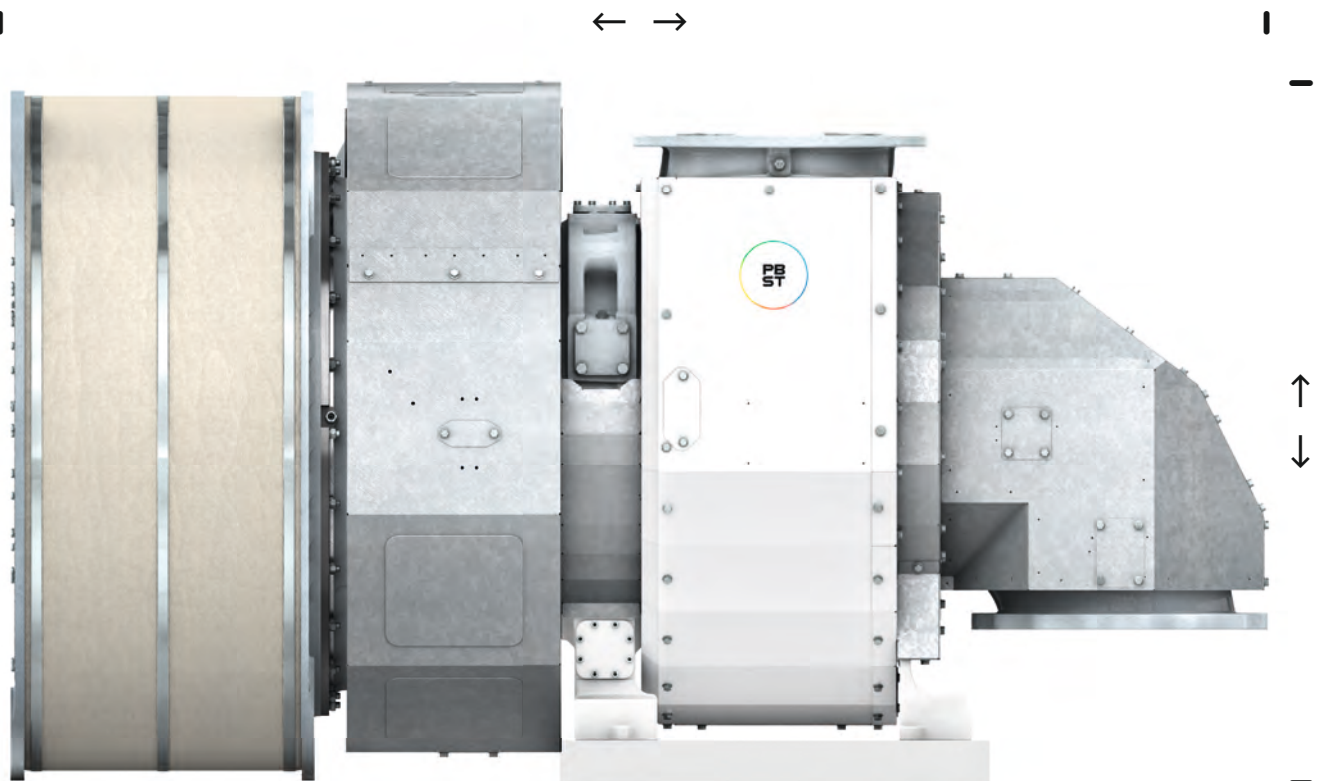



30%

↗ decrease in size, compared to previous turbocharger series



Full performance under environmental pressure

The latest PBST axial turbocharger generation offers significant downsizing together with easier maintenance and higher charging efficiency.

The combination of new and proven design features ensures high charging efficiency, a high specific airflow and a high charging pressure.

Applications

- 4-stroke
- 2-stroke
- Power generation
- Marine
- Two-stage turbocharging

Benefits

- **Higher performance**
5% higher charging efficiency, 10% higher specific airflow and 25% increased charging pressure
- **Reduced cost of ownership**
Extended service lifetime, improved maintenance
Dock to Dock service concept and long service intervals
- **Reliability**
Building on proven components from PBST's 85-year turbocharger heritage such as high-performance plain bearings
- **Compact design**
Up to 40% decrease in weight and 30% decrease in size, compared to previous turbocharger series

Reliable and well-established

TCA

TCA turbochargers are suitable for 4-stroke and 2-stroke gas, diesel and dual fuel engines in applications ranging from 3 MW up to 30 MW output per turbocharger. The TCA generation has been continuously updated since its introduction in 2004. Yet its maintenance and service concept keep ensuring low lifecycle costs. TCA turbochargers are designed to help its applications meet all the latest environmental emissions standards.





Hard-wearing simplicity

TCA turbochargers are high-performance solutions characterized by ease of maintenance and long overhaul intervals. Modular design and a reduced number of components, suitable for all fuels and gases, have contributed to outstanding life cycle costs. TCA turbochargers are made to help ensure its applications are compliant with IMO Tier II and III.

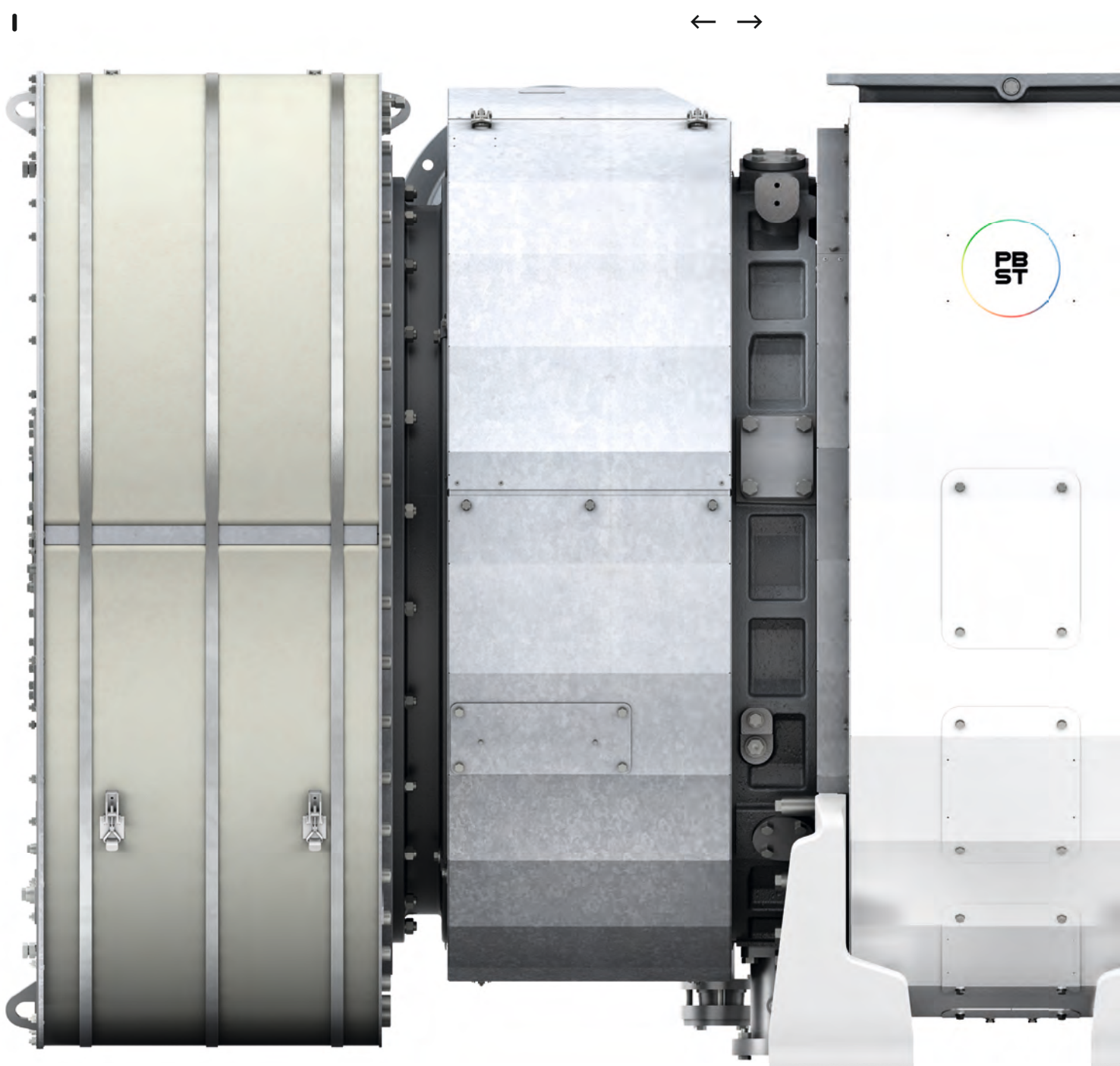

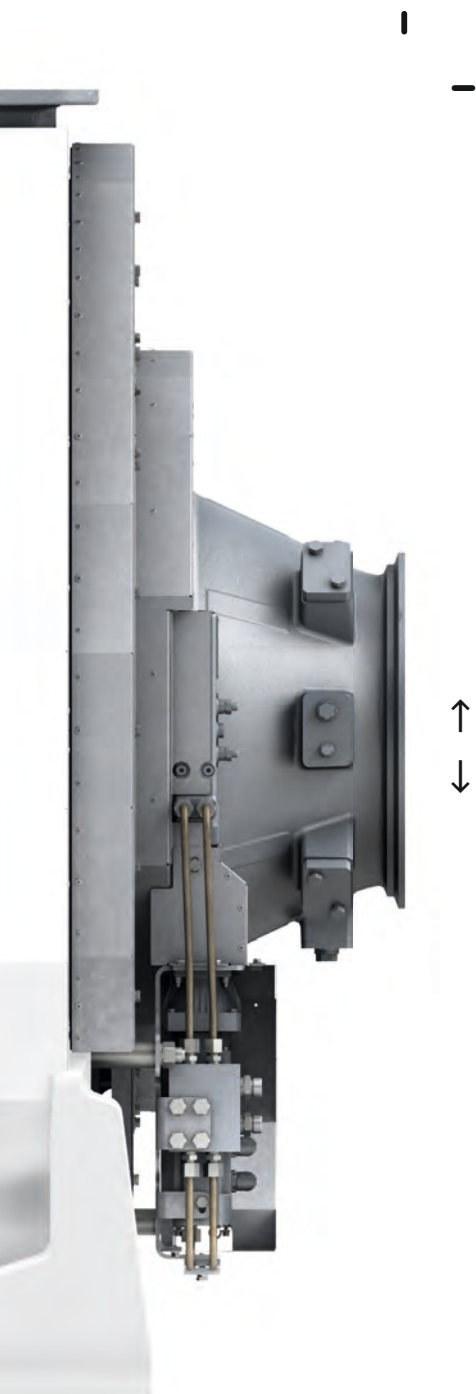

Benefits

- **Long intervals between overhauls and long component life**
Drydock-to-drydock operation
- **Condition-based component maintenance**
Parts are replaced on the basis of component condition, increasing component life and reducing costs
- **Easy to maintain and service**
Maintenance can be carried out with standard tools
- **Variable turbine area optionally available**
Airflow through TCA turbochargers can be controlled by VTA technology

Applications

- 4-stroke
- 2-stroke
- Power generation
- Industrial
- Marine

Ready for the future with enhanced performance and efficiency

TCP

The TCP series of radial turbochargers can achieve maximum pressure ratios of up to 7, a benchmark figure that sets new industry standards.

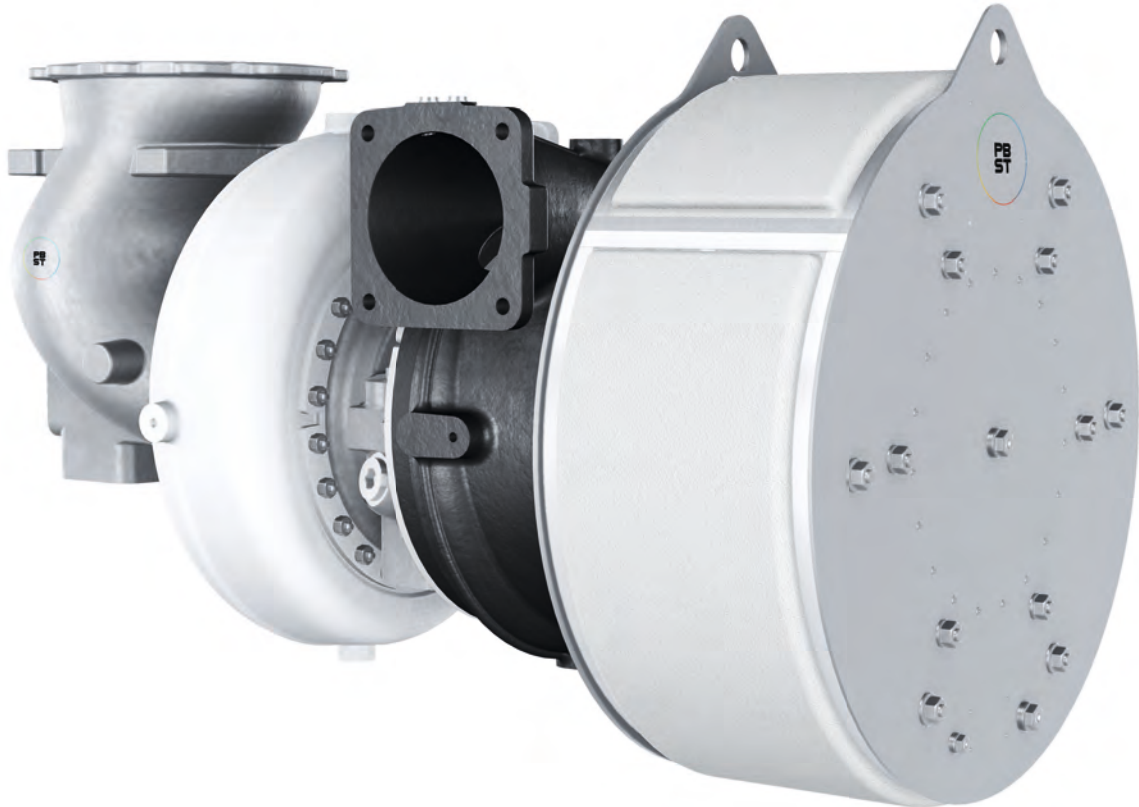

While existing 1-stage turbocharger systems typically deliver pressure ratios of well above 5, the TCP range achieves stable operating points of well above 6. These remarkable figures are thanks to a complete redesign of the aerodynamic stages on both the compressor and turbine side.

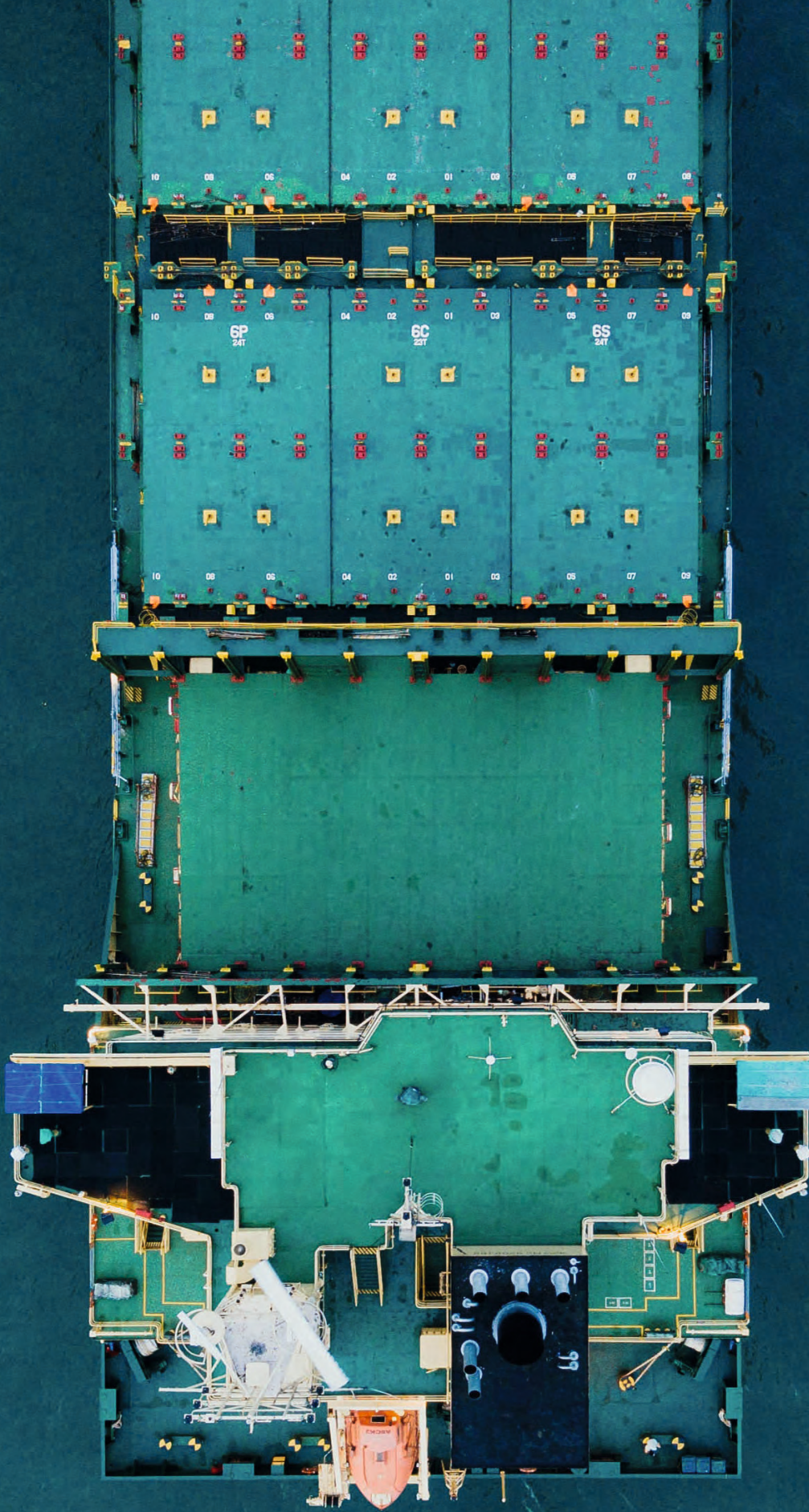

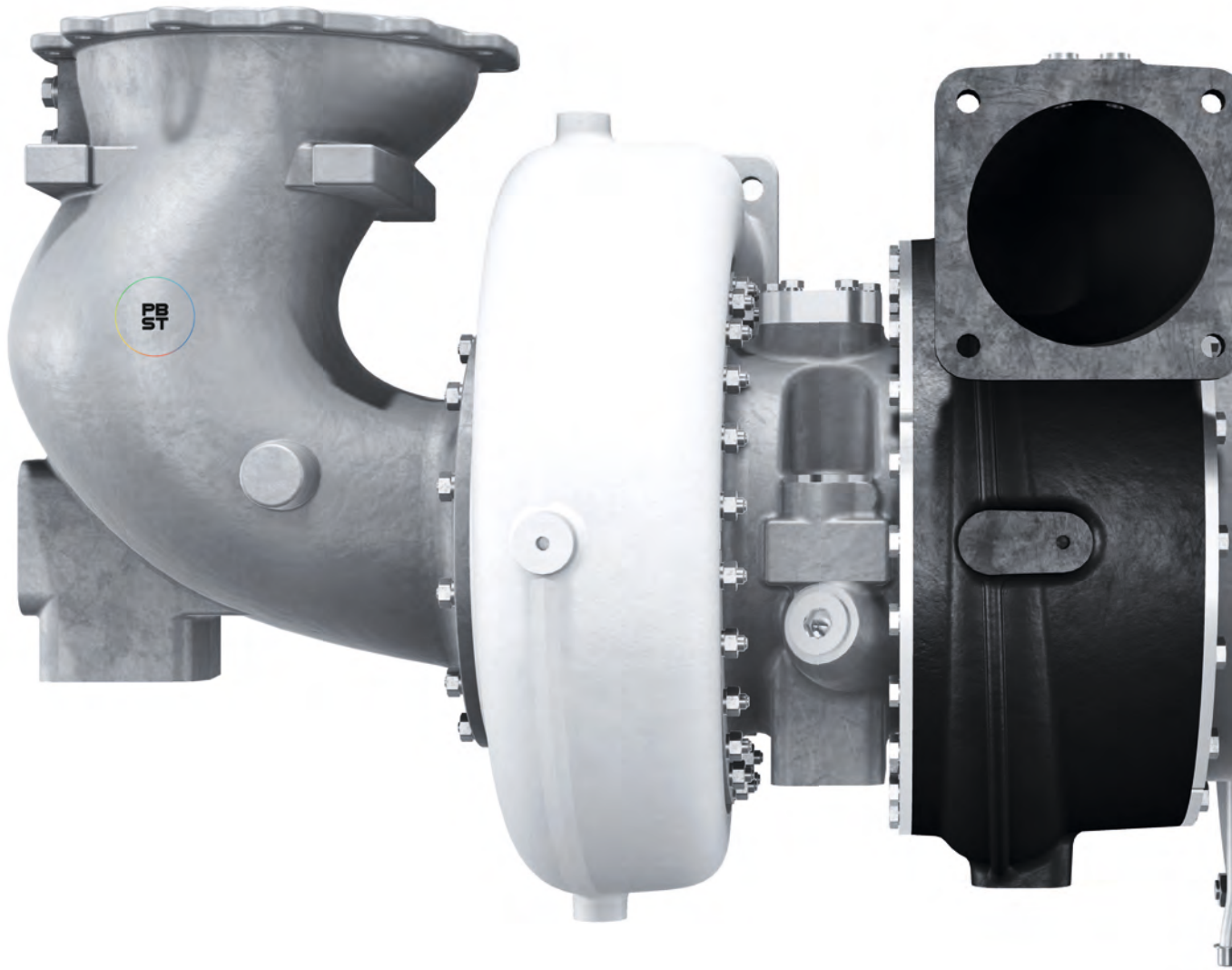

Taking performance to the next level

The TCP range is the key-enabler for increases in power output of around 20%. That translates to increased power at a similar cost, or a smaller engine or fewer cylinders for the same output.

When creating aerodynamic and structural mechanical models for the TCP series, PBST development teams used advanced numerical simulations, which are driven by the ongoing trend towards faster computer processing capability. They were thus able to create highly complex simulations, used as the basis for targeted optimization of flow components, enhanced turbocharger performance and longer working life.



↗ Seven frame sizes, to cover a wide range of applications

Benefits

- Increase in power density of up to 20%
- Decrease of specific engine costs up to 20%
- Improved efficiency levels of > 70%
- Significantly improved dynamic behavior:
25% reduction in rotor moment of inertia
- Plug & play
Keep same flange connections as existing turbochargers
- Improved cost of ownership:
Long time between overhauls
- Maintenance-friendly

Applications

- High- and medium-speed engines
- Conventional and future fuels
- Power
- Marine
- Off-road

Making the most of **optimized** flow

TCF

Delivering an impressive 20% increase in specific flow, the TCF radial turbocharger offers a big potential to use smaller or less turbochargers. Specifically designed to deliver highest efficiencies, the TCF family is particularly suitable for optimization at part load.

Initial studies show that significantly improved fuel consumption figures are achievable with TCF turbochargers. In one study, with a TCF retrofit and engine optimization package, fuel consumption in the relevant operating range was reduced by 4.5%. TCF turbochargers can also help reduce engine emissions, for improved compliance with regulations such as EEXI (Energy Efficiency Existing Ship Index).

Applications

- High-, medium- and low-speed engines
- Suitable for low-speed engines as well as LP-stage for two-stage turbocharging
- Conventional and future fuels
- Power
- Marine
- Off-road

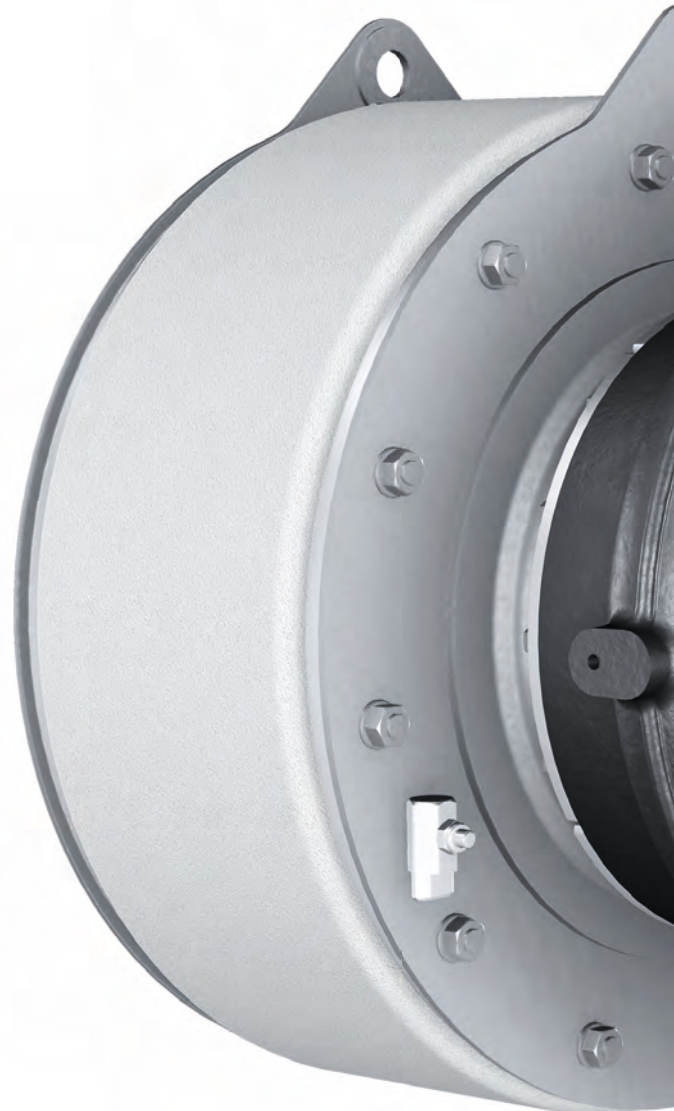

25%

↗ reduction in rotor moment
of inertia

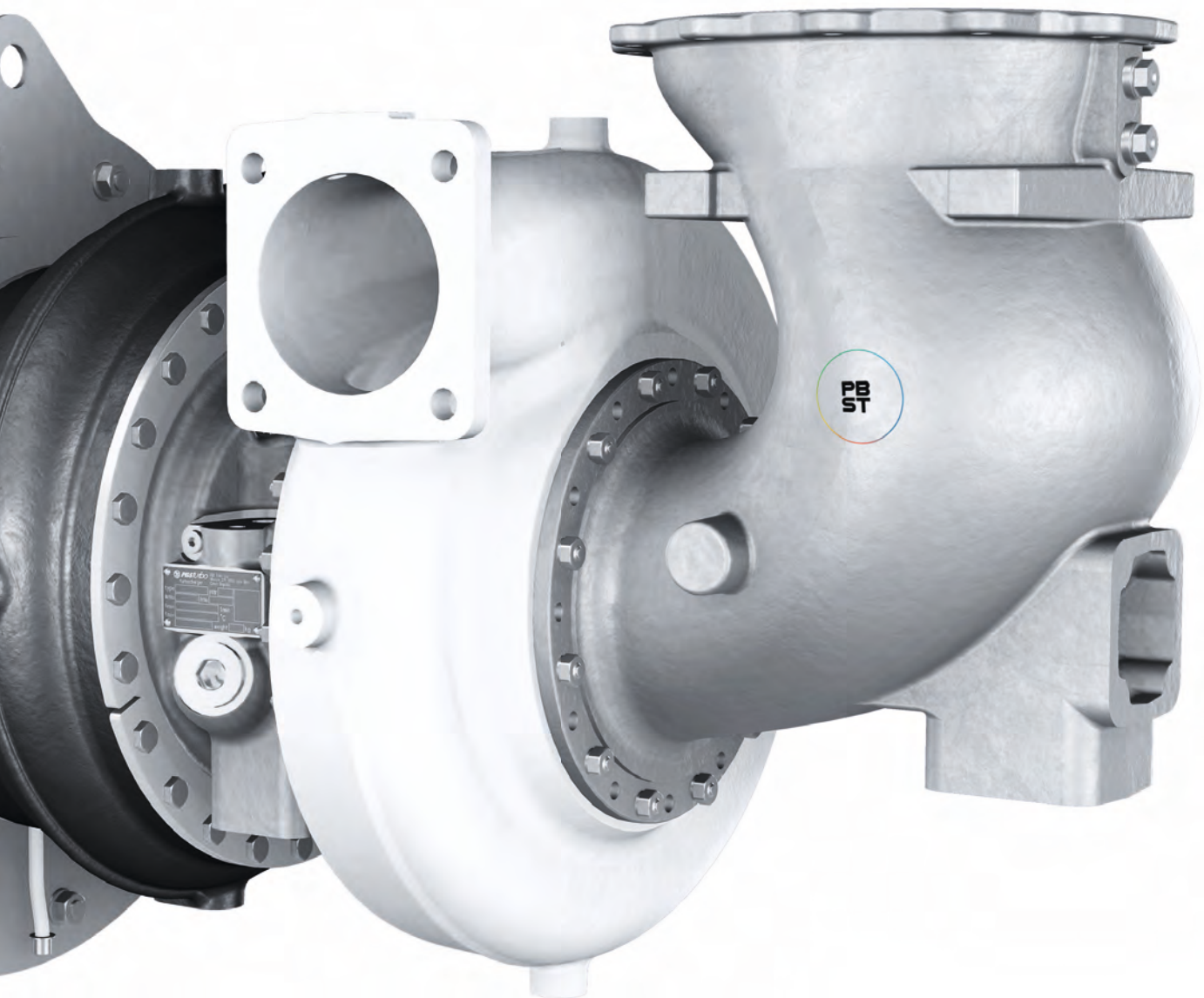

Moving ahead with the TCF series

Due to the outstanding part load performance the big TCF frame sizes in addition are heading for turbocharging the small bore 2-stroke applications.

TCF turbochargers are easy to retrofit thanks to the modular construction and standard connection dimensions, and can help reduce the cost of ownership, with long time between overhauls and a maintenance-friendly design.

The TCF series is also designed for use as the low-pressure-stage turbocharger in two-stage applications, helping to reduce size or the number of turbochargers required and thereby create potential for cost savings.

Benefits

- 20% increase in specific flow
- Potential to use smaller or less turbochargers
→ cost savings
- Highest efficiencies at part load
- Significant reductions in fuel consumption and emissions
- Significantly improved dynamic behavior:
25% reduction in rotor moment of inertia
- Same standard connection dimensions as previous turbochargers



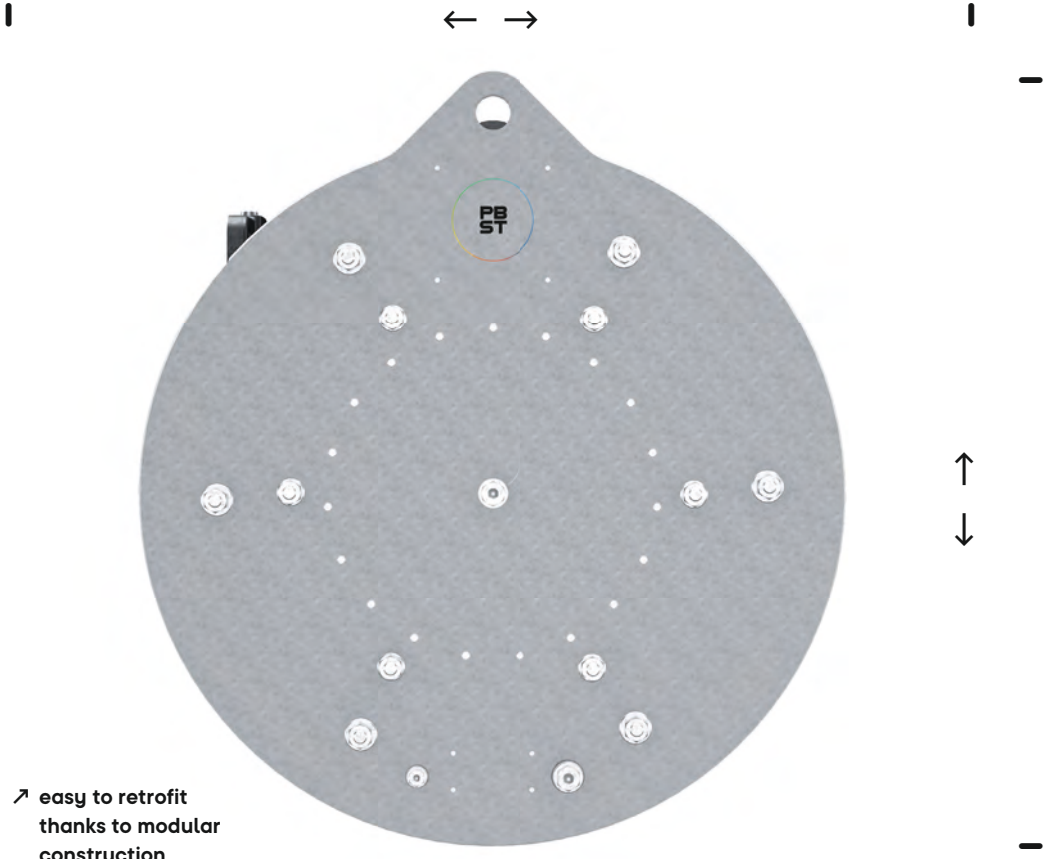

Meet the market leader

ECOCHARGE

ECOCHARGE two-stage turbocharging offers outstanding flexibility as PBST turbocharger families can be freely combined. It is suitable for high and medium speed engines of all fuel types in applications for all engine power ranges. Extremely high efficiency and pressure ratios enable increased power density and allow improvements to key engine parameters. For example, it is possible to use a smaller engine for the same required power output, or to achieve lower NO_x emissions and lower specific fuel oil consumption (SFOC).

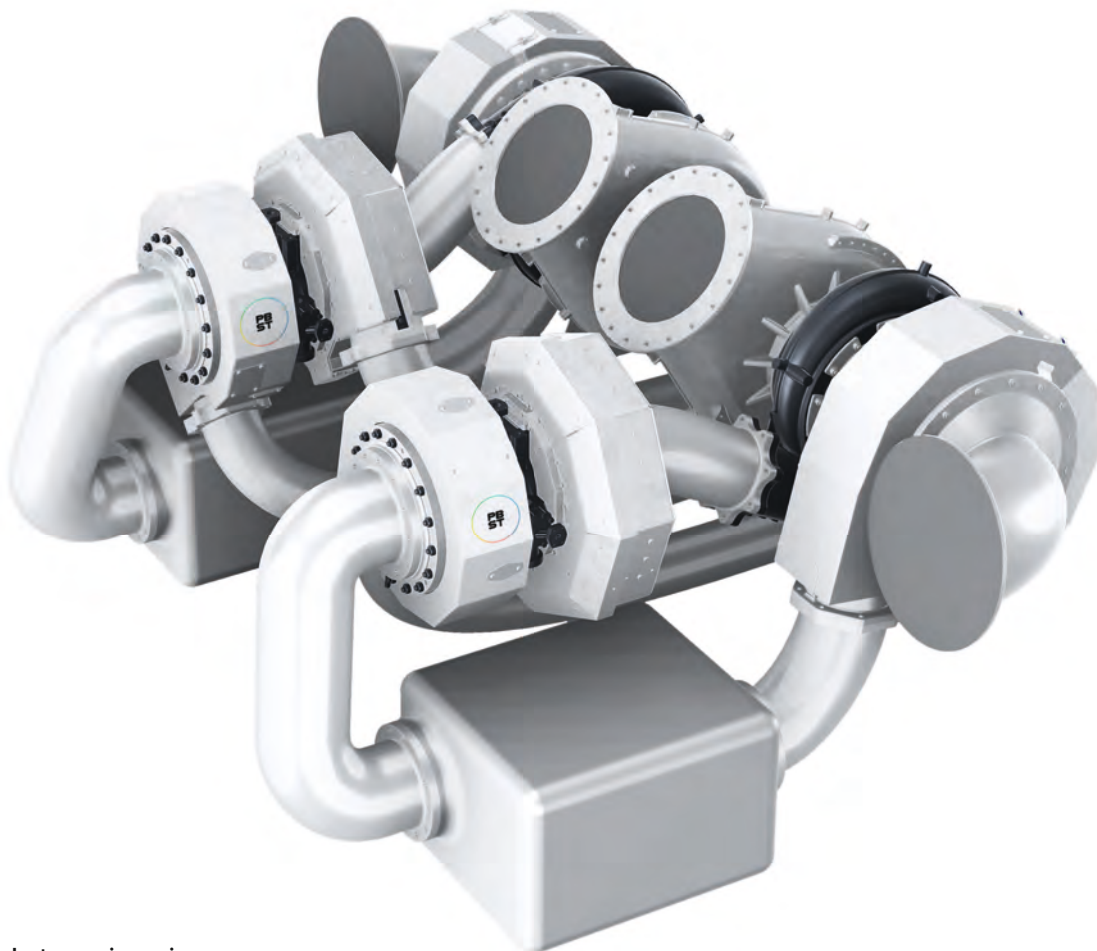



Two-stage turbocharging

As a compact two-stage unit, the ECOCHARGE delivers outstanding turbocharging efficiency. A variety of product types and sizes are available, ensuring the perfect turbocharger-to-engine fit. Higher scavenging air pressure and efficiency allow improved Miller timing, enabling compliance with IMO Tier III emissions legislation.

Benefits

- **Two-stage turbocharging according to your needs**
Free combination of radial and axial turbochargers, as well as size and quantity
- **Lower specific fuel oil consumption (SFOC)**
Increased turbocharging efficiency for reduced SFOC
- **Lower exhaust emissions (NO_x)**
Higher scavenging air pressures of up to 10.5 bar allow improved Miller timing with lower NO_x emissions
- **Compact design**
Integrated modular design reduces the overall dimensions of the ECOCHARGE unit
- **Improved dynamic response**
Smaller high-pressure stage turbocharger with reduced mass inertia for improved dynamic response

Applications

- Marine
- Power generation
- Locomotives
- Off-road

- |

← →

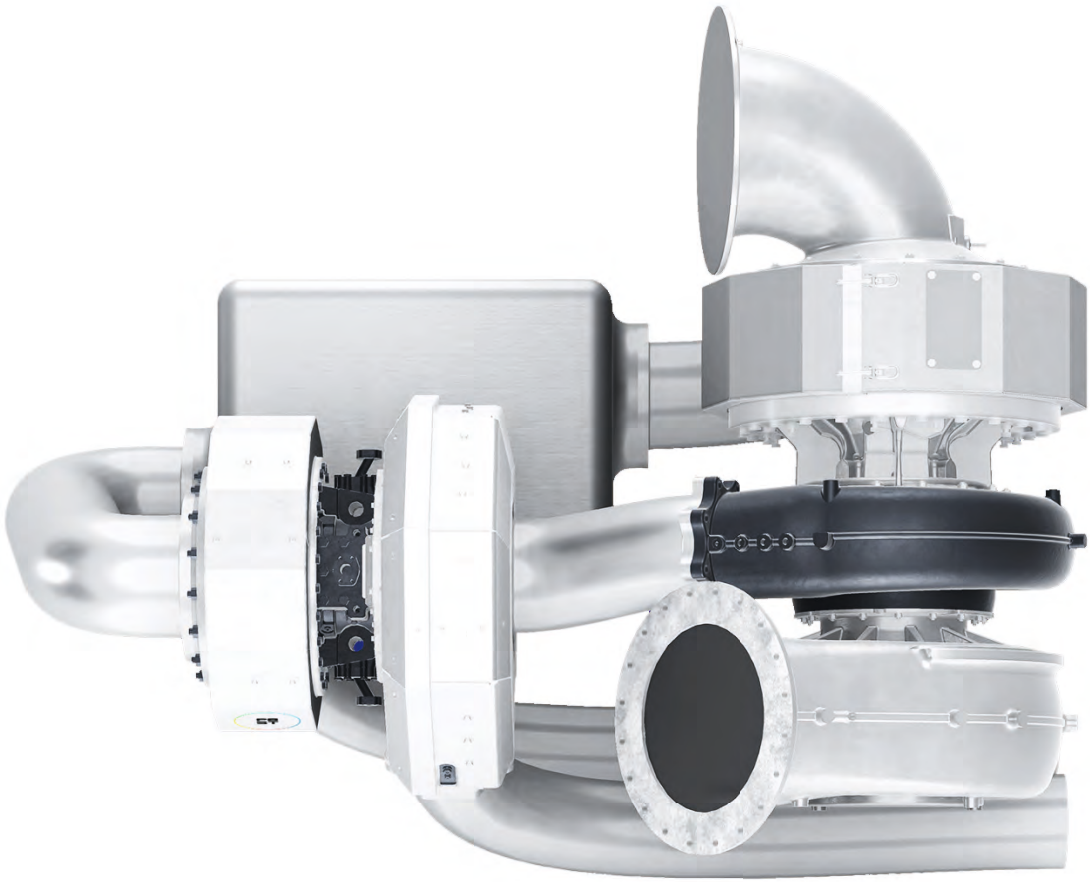

↑ ↓

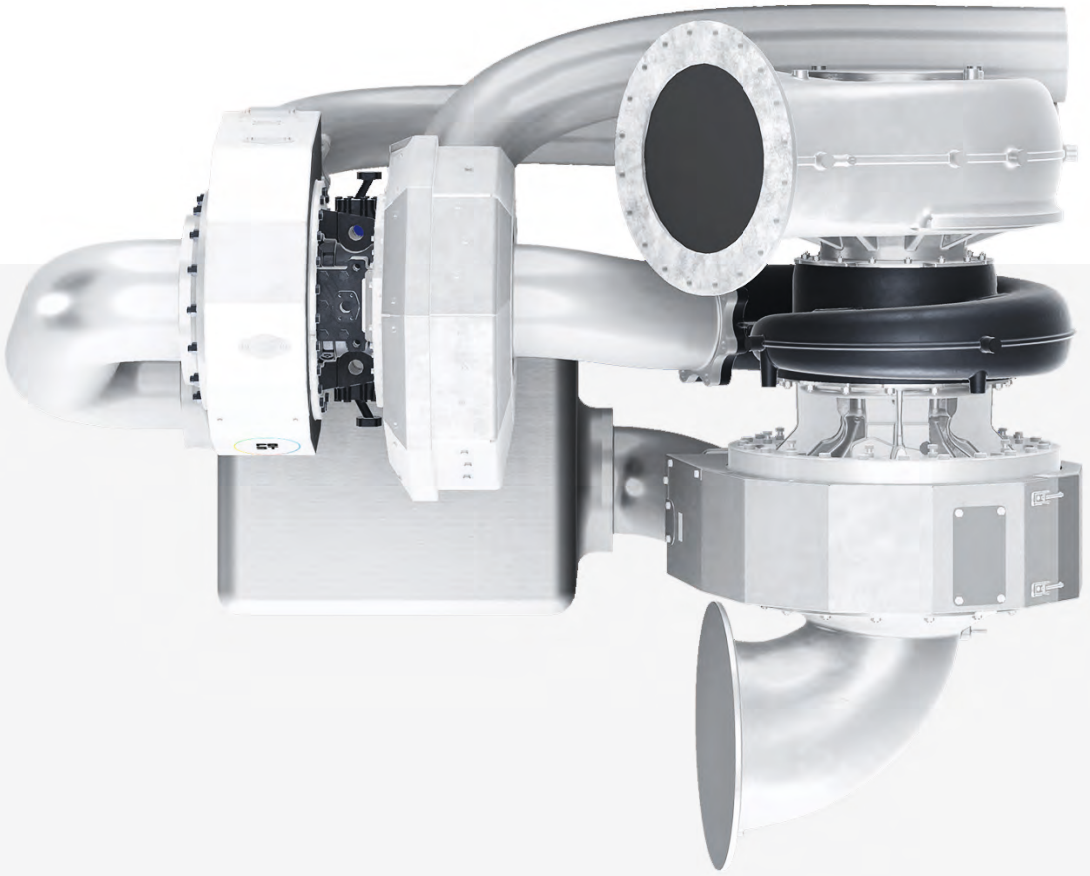

Flexible turbocharging

VTA

The VTA system can be optionally fitted to both TCA and TCR turbochargers. It enables the charge air volume to be precisely matched to the quantity of injected fuel across all points of an engine's load and speed range. The result is increased engine efficiency, reduced SFOC, lower HC and CO₂ emissions and improved engine response. The result is increased engine efficiency, reduced specific fuel oil consumption (SFOC), lower hydrocarbon and CO₂ emissions and improved engine response.



Minimizing consumption and emissions

VTA (variable turbine area) allows charge air delivery to be optimized to demand for charge air precisely and continuously at all engine loads and speeds. VTA minimizes fuel consumption and related exhaust emissions.

Flexible air and fuel management is key to meeting the emissions legislation of the future while increasing engine performance and reducing SFOC. Hence VTA technology has a powerful and positive role to play.

Benefits

- **Reduced consumption**
Up to 5 g/kWh lower fuel consumption
- **Reduced emissions**
Lower soot and smoke emission and lower particle emissions
- **Easy application**
Suitable for TCA and TCR turbochargers and retrofit packages



Cutting NO_x in after-treatment

SCR-HP, SCR-LP, SCR-LPH

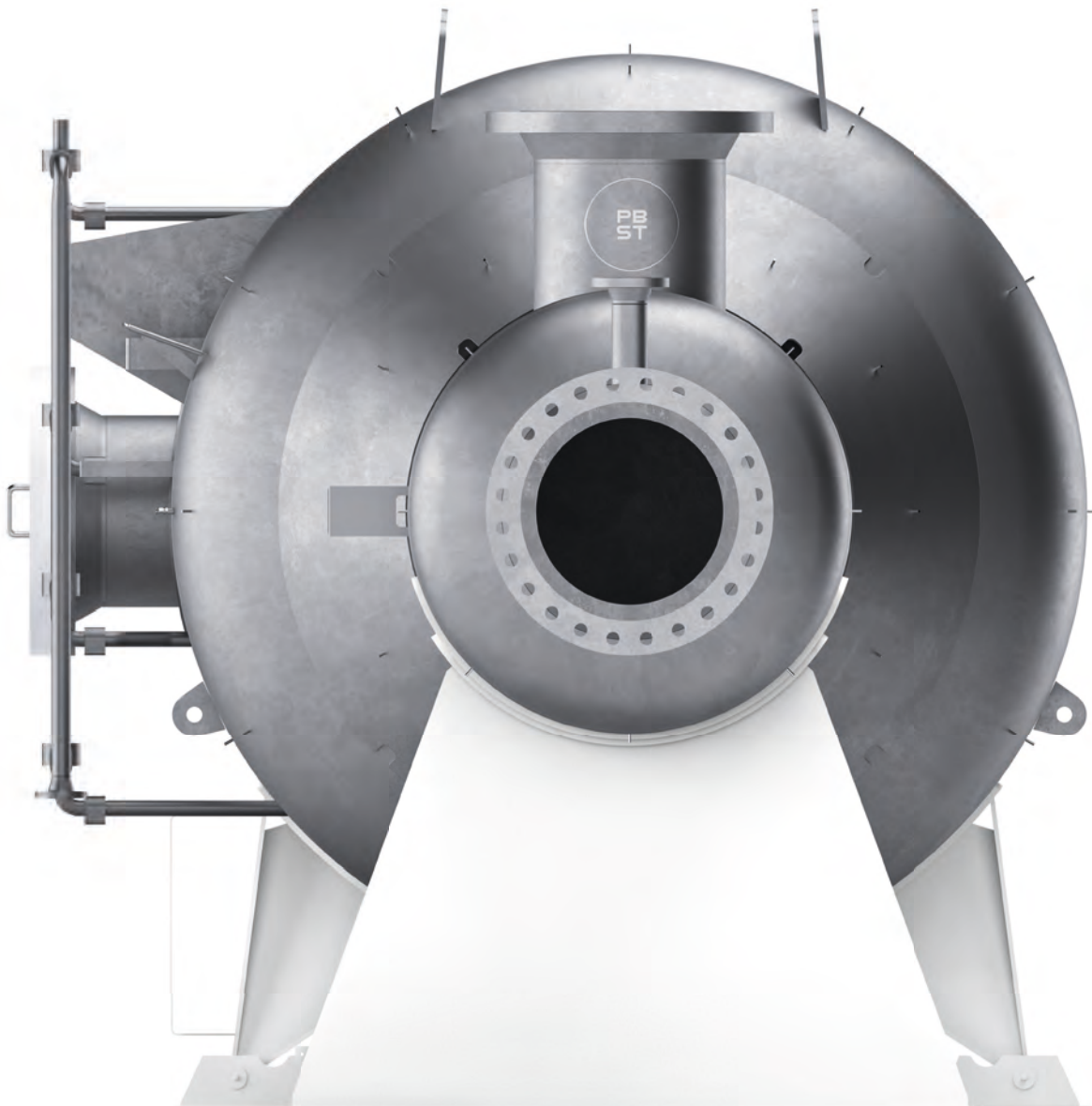

The SCR-HP system is the world's smallest and most compact NO_x emission reduction system. The compact design allows for easy integration, and the few frame sizes will cover the entire 2-stroke portfolio up to 25 MW per SCR reactor. The integrated mixing unit reduces the overall length and volume; specific catalyst elements ensure a compact design. Auxiliary components like the urea injection lance, urea dosing unit and urea pump module are from our parent company MAN Energy Solutions' well-proven SCR-LP system.

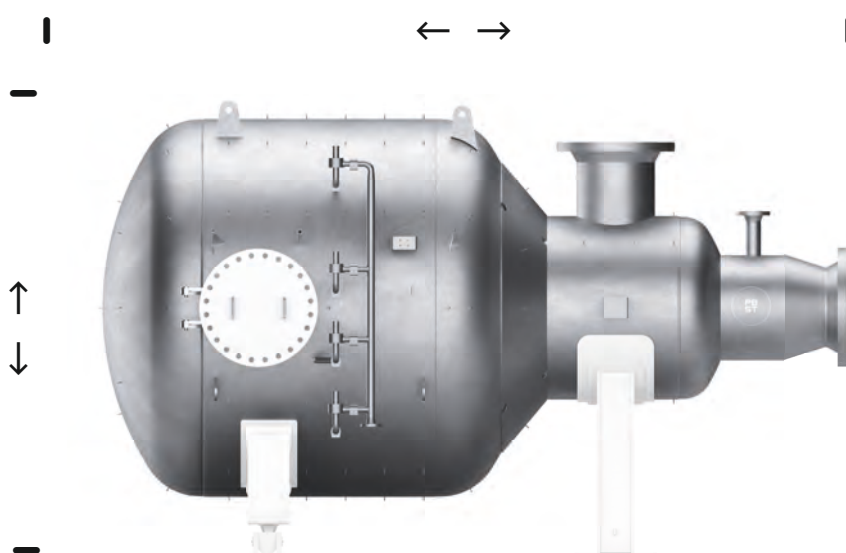

Applications

→ 2-stroke

→ 4-stroke

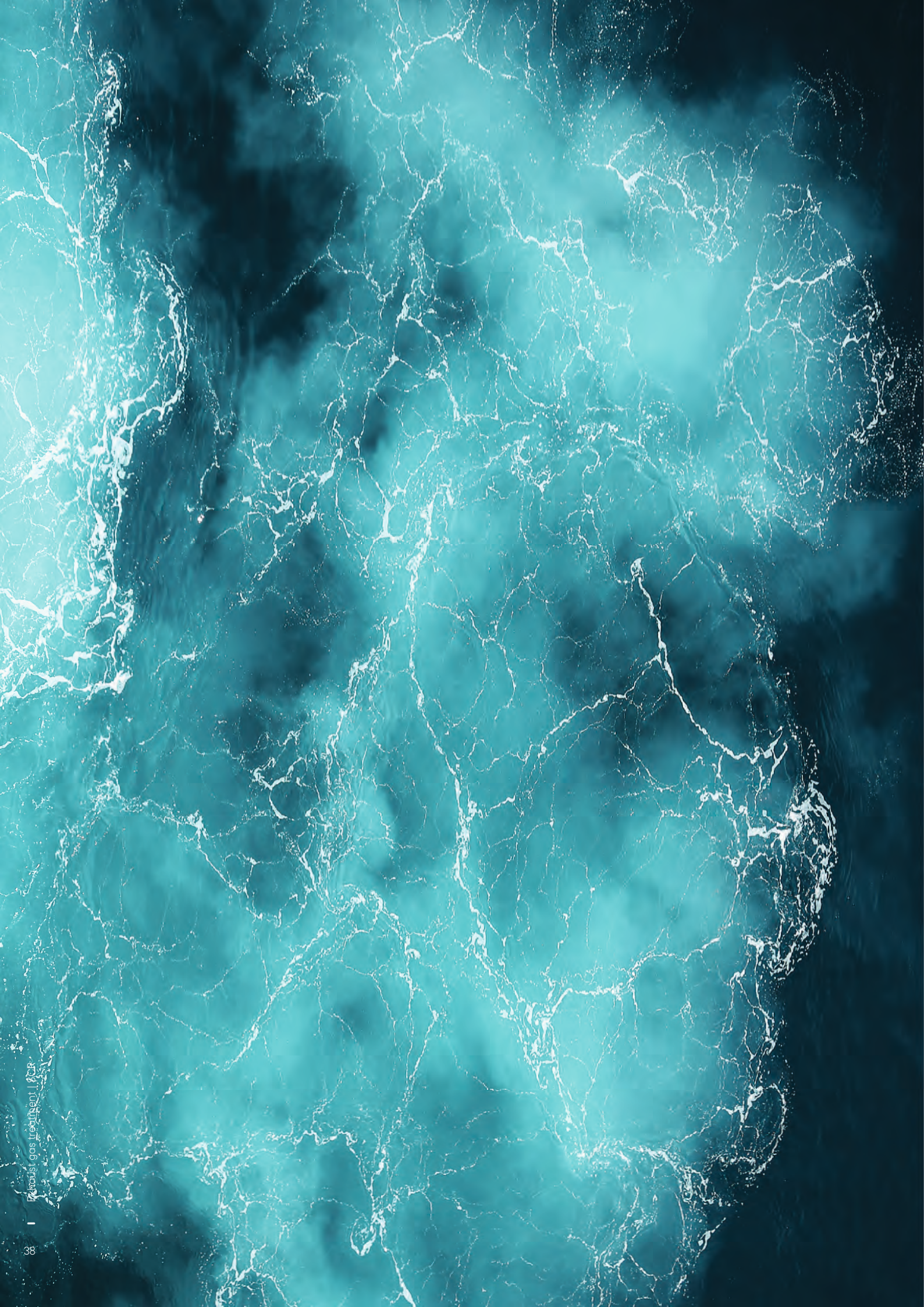

High-pressure selective catalytic reduction

The SCR-HP is available for 2-stroke engines of all bore sizes and reduces – through selective catalytic reduction – NO_x exhaust emissions to IMO Tier III limits. With specially developed catalyst elements in honeycomb style, as well as an integrated mixing unit, the overall size of the reactor has been drastically reduced compared to low pressure SCR systems.

Benefits

→ Improved compact design

The improved compact design, compared to conventional reactors, leads to considerable benefits for engine builders, shipyards and ship owners

→ One-source solution

PBST is the only manufacturer capable of delivering turbocharger, exhaust gas after-treatment solutions and injections systems within the 2-stroke sector: high-pressure selective catalytic reduction and exhaust gas recirculation – including an electrical turbo blower. This allows 2-stroke customers to choose their preferred option as best fits their situation.

→ Proven technology

The development of the new system is based on our in-house competence with 4-stroke engines, for which it can already reference more than 650,000 operating hours.

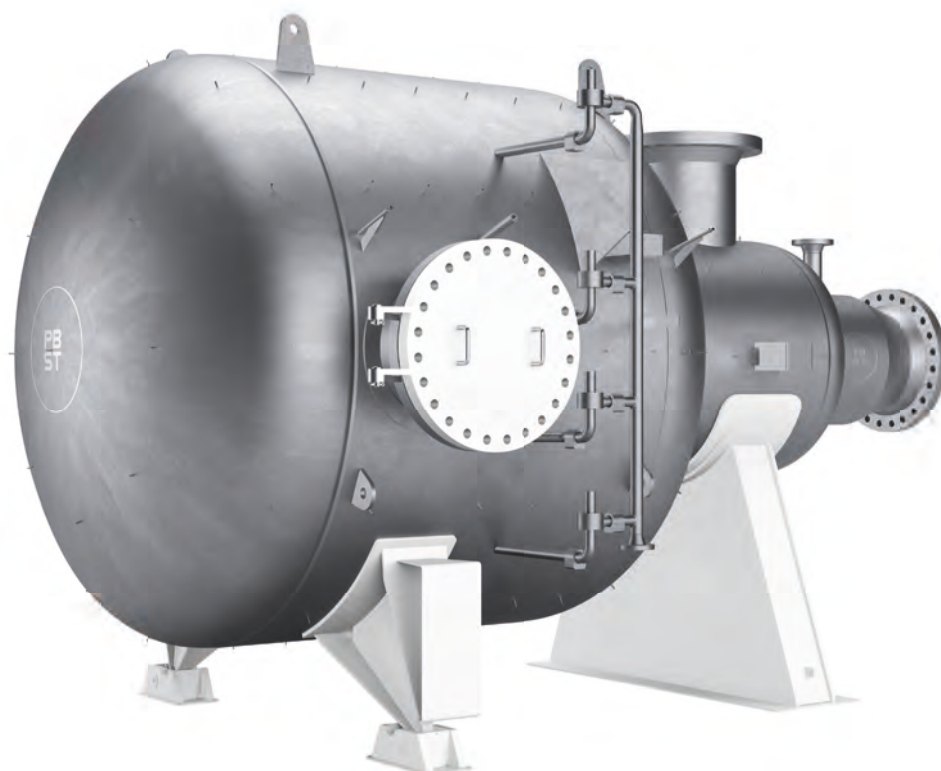

Robust IMO Tier III performance

ETB

The EGR blower ETB is suitable for exhaust gas recirculation (EGR) engines of all fuel types in all application ranges. Specifically designed for EGR systems, the ETB's active control plays an important role in enabling these systems to reach IMO Tier III emission standards. The required EGR operating conditions are achieved by using a high speed electric motor directly coupled to the compressor wheel and controlled by a frequency converter.

Reducing NO_x through recirculation

The ETB features a highly efficient blower wheel, optimized for low pressure ratios and to withstand exhaust gas. The blower helps to lower emissions by recirculating the exhaust gas into the combustion chamber, where it is an inert gas that helps to prevent the formation of NO_x. The materials used are designed to withstand corrosive agents. High blower availability and variable speed operation ensure IMO Tier III compliance in emission control areas (ECAs).

Benefits

- **Low consumption**
Improved thermodynamic efficiency allows extremely low energy consumption
- **High durability**
All materials have been designed for highly corrosive atmospheres
- **Smart control for stable EGR flow**
EGR flow is controlled by a high speed electric motor. The ETB is integrated into the engine control system.

Applications

→ 2-stroke

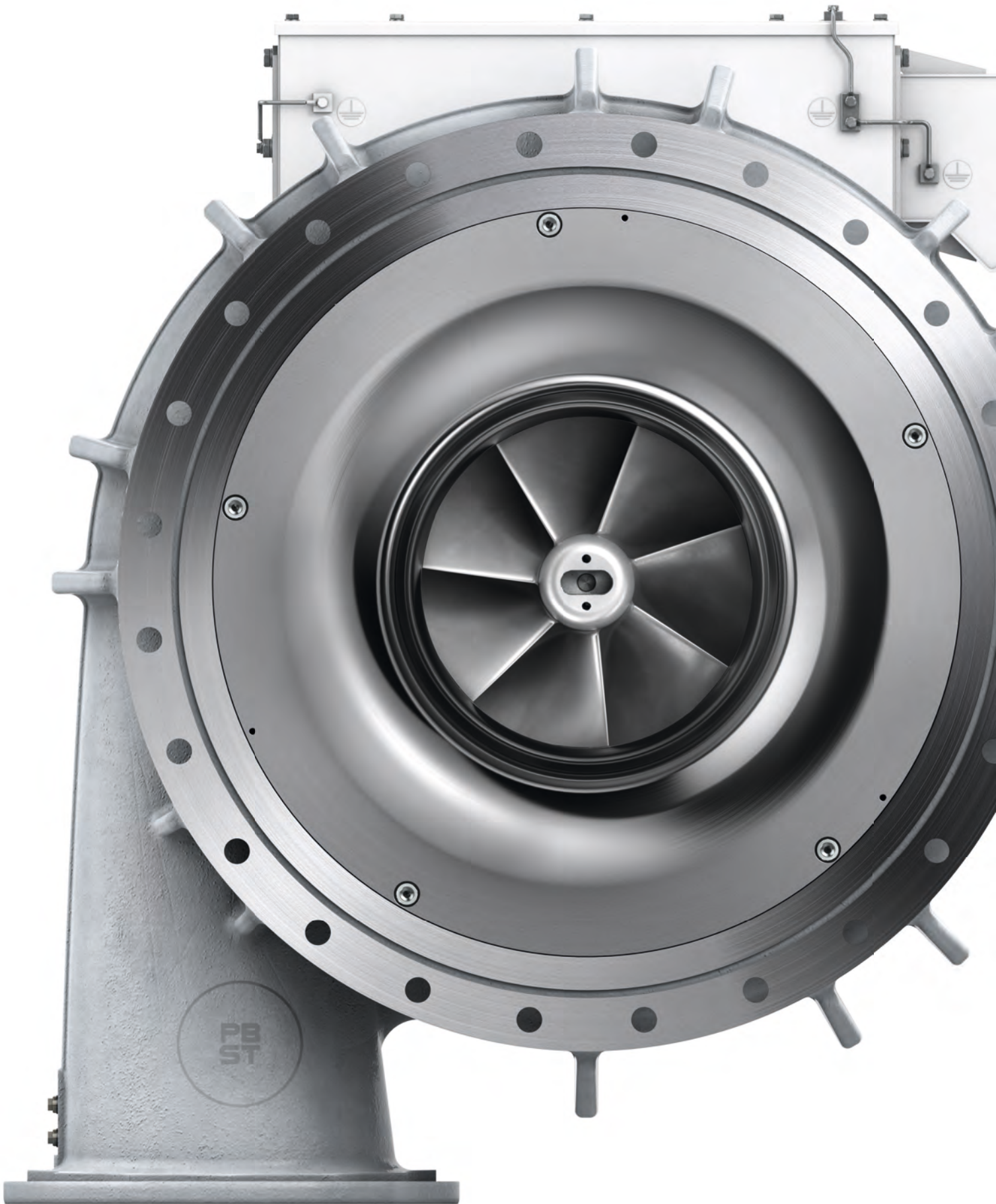

↗ Exhaust gas
recirculation blower

Performance **starts** here

The latest generation of PBST injection systems offer best performance and full flexibility for your application.

Get set for a boost in performance: PBST's new injection systems are specifically designed to offer best performance and full flexibility for your application. Reductions in soot of up to 50% are achievable for less environmental impact. In addition, undesirable mechanical loads and engine noise are reduced for a longer lifetime period. Innovative systems ensure future fuel consideration and validation.

Easy to retrofit thanks to a compact and modular design, our new injection systems are also easy to maintain and service: plug & play injectors ensure problem-free handling for less downtime and lower maintenance costs.

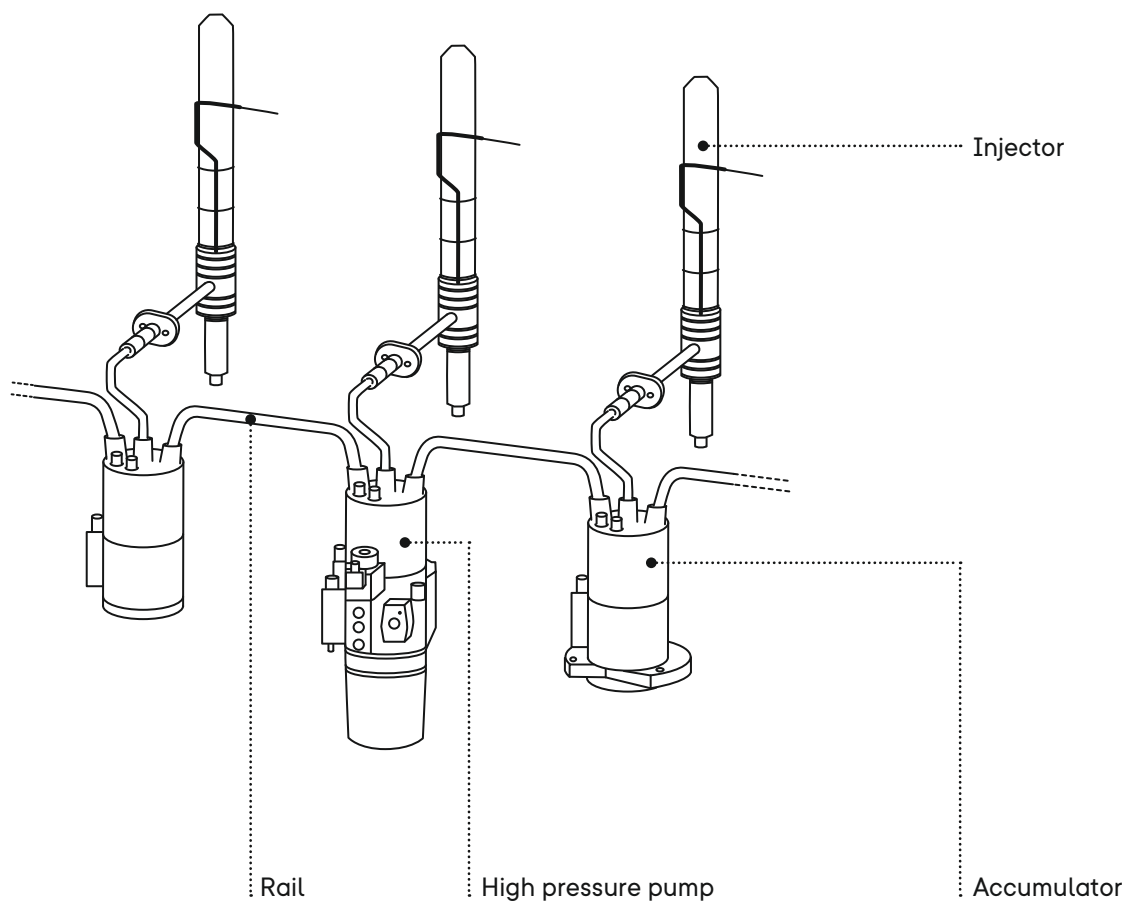

Benefits

- High pressure
- Variable injection timing;
multiple injection
- Improved dynamic behavior
- Significant improvements in fuel
efficiency compared to previous
injection systems
- Up to 50% less soot
- Biofuel readiness
- Compact and modular design
suitable for many different types
of application
- Easy to retrofit
- Easy to maintain and service
(plug & play injectors, less downtime)

Applications

- 4-stroke
- Marine
- Power generation

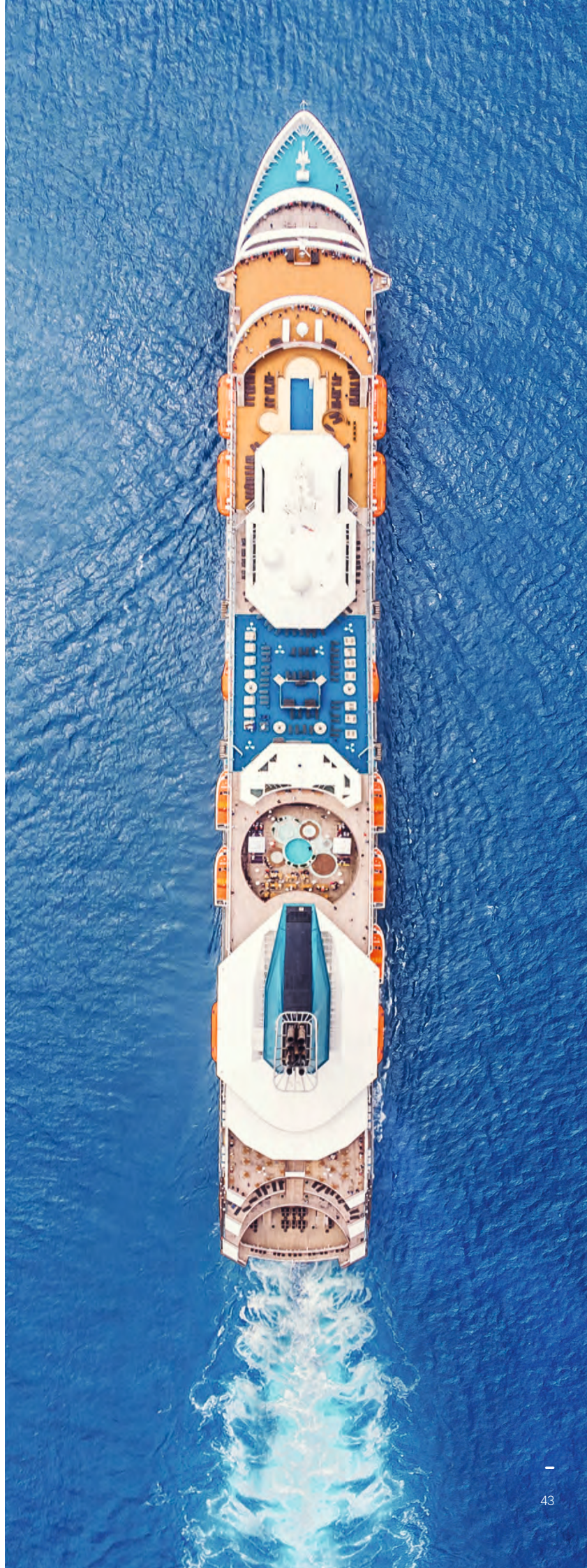



Service with passion

MAN PrimeServ

MAN PrimeServ is PBST's authorized service brand. Via a network of over 100 service centers worldwide, MAN PrimeServ provides 24/7 service across the globe. Our range of services includes technical support, consulting and OEM spares, as well as maintenance, repair and comprehensive individualized service plans.

24 hours
↗ a day

365 days
↗ a year

Ambition

- Prompt delivery of high-demand OEM spare parts within 24 hours
- Fast, reliable and competent customer support
- Individually tailored O&M contracts
- Ongoing training and qualification of operators and maintenance staff
- Global service, 24 hours a day, 365 days a year
- Diagnosis and troubleshooting with our high-performance online service

We offer retrofitting and upgrade services to bring turbochargers already in service up to the very latest standards of performance and efficiency.

Using the latest digital technology, we enable you to maximize the performance and availability of your PBST equipment by accessing real-time data analysis, remote support and rapid solutions. We also offer an extensive range of training courses at MAN PrimeServ academies around the world.

Our service does not vary according to location. We know that a vessel may be built in Asia, operated in Europe for ten years and then move to Africa for the next ten years. That does not alter our focus on dedicated training, fast delivery of strategic spare parts, a comprehensive approach or our tailored maintenance contracts.

For more information please visit
→ www.man-es.com/primeserv

100
↑ service centers
worldwide





↗ **PBST**
86224 Augsburg
Germany

↗ **air-management@pbst.eu**
www.pbst.eu

All data provided in this document is non-binding. This data serves informational purposes only and is not guaranteed in any way. Depending on the subsequent specific individual projects, the relevant data may be subject to changes and will be assessed and determined individually for each project. This will depend on the particular characteristics of each individual project, especially specific site and operational conditions.